

General Description

The Sanrise SRC60R090BS is a high voltage power MOSFET, fabricated using advanced super junction technology. The resulting device has extremely low on resistance, low gate charge and fast switching time, making it especially suitable for applications which require superior power density and outstanding efficiency.

The SRC60R090BS break down voltage is 600V and it has a high rugged avalanche characteristics.

The SRC60R090BS is available in TO-263-2 , TO-220F, TO-220C and TO-247 packages.

Features

- Ultra Low $R_{DS(ON)} = 90m\Omega @ V_{GS} = 10V$.
- Ultra Low Gate Charge, $Q_g=90.3nC$ typ.
- Intrinsic Fast-Recovery Body Diode
- Fast switching capability
- Robust design with better EAS performance
- Non-automotive Qualified
- Ultra-fast body diode

Application

- AC/DC Power Supply
- EV Charger
- PC / Sever / Telecom
- Solar Inverter

Ordering Information

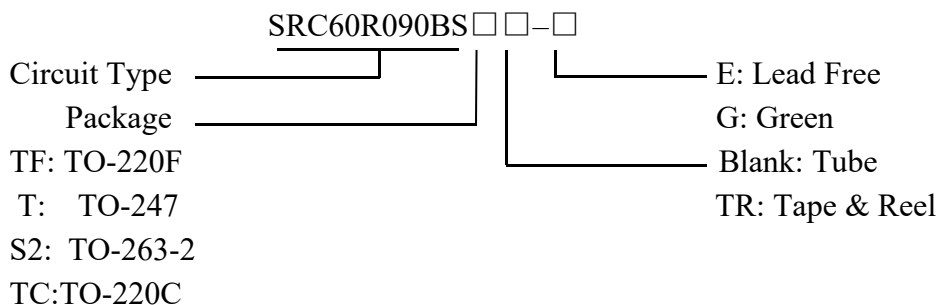

Symbol

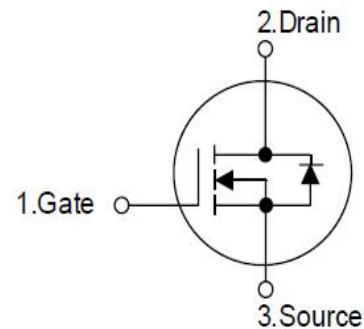

Figure 1 Symbol of SRC60R090BS

Package Type

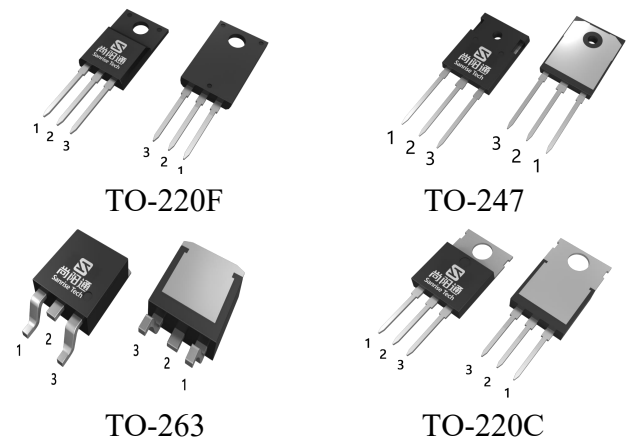

Figure 2 Package Types of SRC60R090BS

Package	Part Number		Marking ID		Packing Type
	Lead Free	Green	Lead Free	Green	
TO-220F	SRC60R090BSTF-E	SRC60R090BSTF-G	SRC60R090BSTFE	SRC60R090BSTFG	Tube
TO-247	SRC60R090BST-E	SRC60R090BST-G	SRC60R090BSTE	SRC60R090BSTG	Tube
TO-263-2	SRC60R090BSS2TR-E	SRC60R090BSS2TR-G	SRC60R090BSS2E	SRC60R090BSS2G	Tape & Reel
TO-220C	SRC60R090BSTC-E	SRC60R090BSTC-G	SRC60R090BSTCE	SRC60R090BSTCG	Tube

Absolute Maximum Ratings

Parameter		Symbol	Rating	Unit
Drain-Source Voltage		V_{DSS}	600	V
Gate-Source Voltage		V_{GSS}	±30	V
Gate-Source Voltage, AC ($f > 1$ Hz)		V_{GSS}	±30	V
Continuous Drain Current	$T_C = 25^\circ\text{C}$	I_D	42	A
	$T_C = 100^\circ\text{C}$		26.4	
	$T_C = 125^\circ\text{C}$		18.7	
Pulsed Drain Current (Note 2)		I_{DM}	126	A
Avalanche Energy, Single Pulse (Note 3)		E_{AS}	160	mJ
Avalanche Energy, Repetitive (Note 2)		E_{AR}	0.2	mJ
Avalanche Current, Repetitive (Note 2)		I_{AR}	2.2	A
Continuous Diode Forward Current		I_S	42	A
Diode Pulse Current		$I_{S,PULSE}$	126	A
MOSFET dv/dt Ruggedness, $V_{DS} \leq 480\text{V}$		dv/dt	80	V/ns
Reverse Diode dv/dt , $V_{DS} \leq 480\text{V}$, $I_{SD} \leq I_D$		dv/dt	50	V/ns
Power Dissipation ($T_C = 25^\circ\text{C}$, TO-220F)		P_{tot}	32	W
Power Dissipation ($T_C = 25^\circ\text{C}$, TO-247, TO-220C, TO-263)		P_{tot}	255	W
Operating Junction Temperature		T_J	150	$^\circ\text{C}$
Storage Temperature		T_{STG}	-55 to 150	$^\circ\text{C}$
Lead Temperature (Soldering, 10 sec)		T_{LEAD}	260	$^\circ\text{C}$

Note:

- Absolute maximum ratings are those values beyond which the device could be permanently damaged. Absolute maximum ratings are stress ratings only and functional device operation is not implied.
- Repetitive Rating: Pulse width limited by maximum junction temperature
- $I_{AS} = 2.2\text{A}$, $V_{DD} = 60\text{V}$, $R_G = 25\Omega$, Starting $T_J = 25^\circ\text{C}$

Thermal Resistance

Parameter		Symbol	Min	Typ	Max	Unit
Thermal resistance, Junction-to-Case	TO-220F	R_{thJC}			3.9	$^\circ\text{C} / \text{W}$
	TO-263-2				0.49	
	TO-247				0.49	
	TO-220C				0.49	
Thermal resistance, Junction-to-Ambient	TO-220F	R_{thJA}			78	$^\circ\text{C} / \text{W}$
	TO-263-2				60	
	TO-247				60	
	TO-220C				60	

Electrical Characteristics
 $T_J = 25^\circ\text{C}$, unless otherwise specified.

Parameter	Symbol	Test Conditions	Min	Typ	Max	Unit
Statistic Characteristics						
Drain-Source Breakdown Voltage	BV_{DSS}	$V_{GS}=0V, I_D=250\mu A$	600			V
Zero Gate Voltage Drain Current	I_{DSS}	$V_{DS}=600V, V_{GS}=0V$			10	μA
Gate-Body Leakage Current	Forward	$I_{GSSF}, V_{GS}=30V, V_{DS}=0V$			100	nA
	Reverse	$I_{GSSR}, V_{GS}=-30V, V_{DS}=0V$			-100	nA
Gate Threshold Voltage	$V_{GS(TH)}$	$V_{DS}=V_{GS}, I_D=800\mu A$	3.0	4.0	5.0	V
Static Drain-Source On-Resistance	$R_{DS(ON)}$	$V_{GS}=10V, I_D=21A$		70	90	mΩ
Gate Resistance	R_G	f=1MHz, Open Drain		0.7		Ω
Dynamic Characteristics						
Input Capacitance	C_{ISS}	$V_{DS}=400V, V_{GS}=0V,$ f=100kHz		3373		pF
Output Capacitance	C_{OSS}			69.4		
Effective output capacitance, energy related ^{NOTE5}	$C_{O(er)}$	$V_{GS}=0V,$ $V_{DS}=0\dots 400V$		98.2		pF
Effective output capacitance, time related ^{NOTE6}	$C_{O(tr)}$			601		
Turn-on Delay Time	$t_{d(on)}$	$V_{DD}=400V, I_D=21A$ $R_G=3\Omega, V_{GS}=10V$		26		ns
Rise Time	t_r			28.4		
Turn-off Delay Time	$t_{d(off)}$			56		
Fall Time	t_f			7.2		
Gate Charge Characteristics						
Gate to Source Charge	Q_{gs}	$V_{DD}=400V, I_D=21A$ $V_{GS}=0$ to 10V		30		nC
Gate to Drain Charge	Q_{gd}			50		
Gate Charge Total	Q_g			104		
Gate Plateau Voltage	$V_{plateau}$			6.6		V
Reverse Diode Characteristics						
Drain-Source Diode Forward Voltage	V_{SD}	$V_{GS}=0V, I_{SD}=21A$		0.9	1.1	V
Reverse Recovery Time	t_{rr}	$V_R=400V, I_F=21A$ $dI_F/dt=100A/\mu s$		169		ns
Reverse Recovery Charge	Q_{rr}			1.33		μC
Peak Reverse Recovery Current	I_{rrm}			14.2		A

Note:

- $C_{O(er)}$ is a fixed capacitance that gives the same stored energy as C_{OSS} while V_{DS} is rising from 0 to 480V
- $C_{O(tr)}$ is a fixed capacitance that gives the same charging time as C_{OSS} while V_{DS} is rising from 0 to 480 V

Typical Performance Characteristics

<p>Figure 3: Power Dissipation</p>  <p>$P_{tot} = f(T_c)$</p>	<p>Figure 4: Max. Transient Thermal Impedance</p>  <p>$Z_{th(jc)} = f(t_p)$; parameter: $D = t_p/T$</p>
<p>Figure 5: Safe Operating Area</p>  <p>$I_D = f(V_{DS}); T_c = 25^\circ\text{C}; V_{GS} > 7\text{V};$ parameter t_p</p>	<p>Figure 6: Safe Operating Area</p>  <p>$I_D = f(V_{DS}); T_c = 80^\circ\text{C}; V_{GS} > 7\text{V};$ parameter t_p</p>

Figure 7: Typ. Output Characteristics

 $I_D = f(V_{DS}); T_j = 25^\circ\text{C}; \text{parameter: } V_{GS}$
Figure 8: Typ. Output Characteristics

 $I_D = f(V_{DS}); T_j = 125^\circ\text{C}; \text{parameter: } V_{GS}$
Figure 9: Typ. Drain-Source On-State Resistance

 $R_{DS(ON)} = f(I_D); T_j = 125^\circ\text{C}; \text{parameter: } V_{GS}$
Figure 10: Typ. Drain-Source On-State Resistance

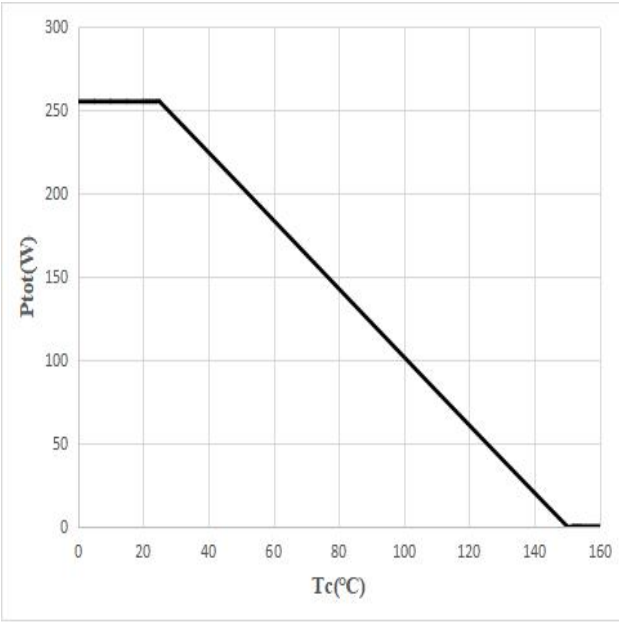
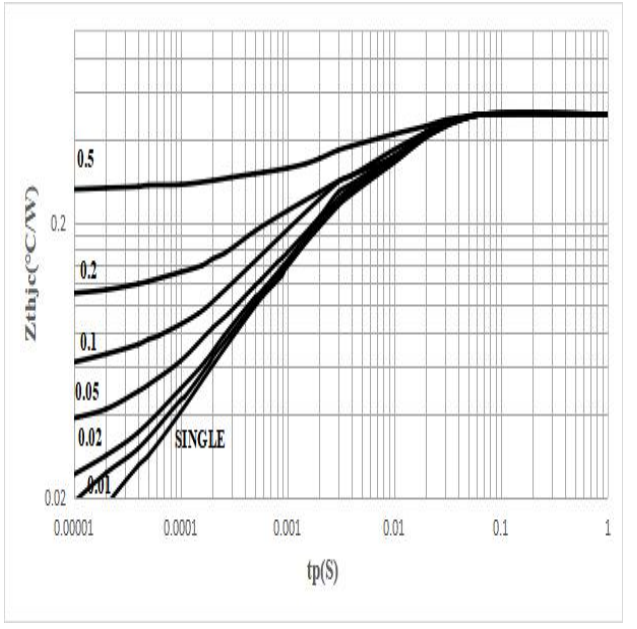
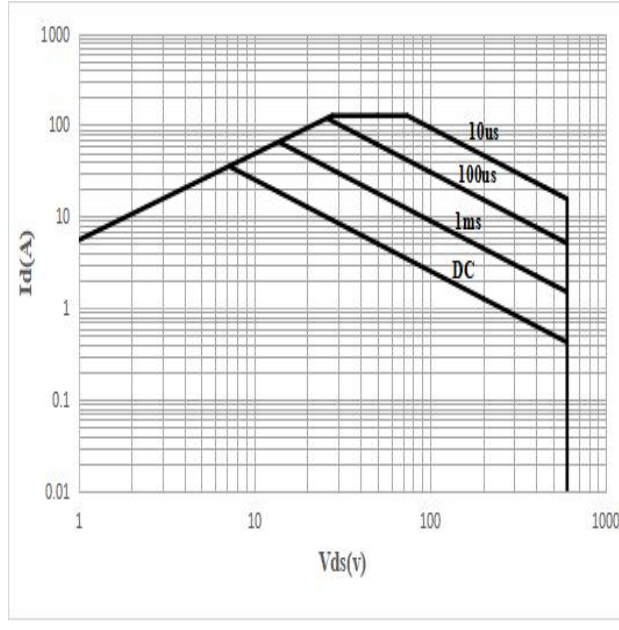
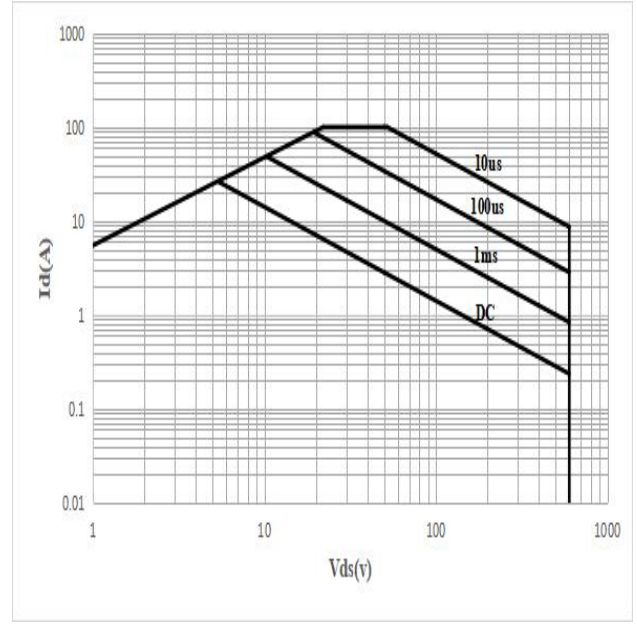
 $R_{DS(ON)} = f(T_j); I_D = 21\text{A}; V_{GS} = 10\text{V}$

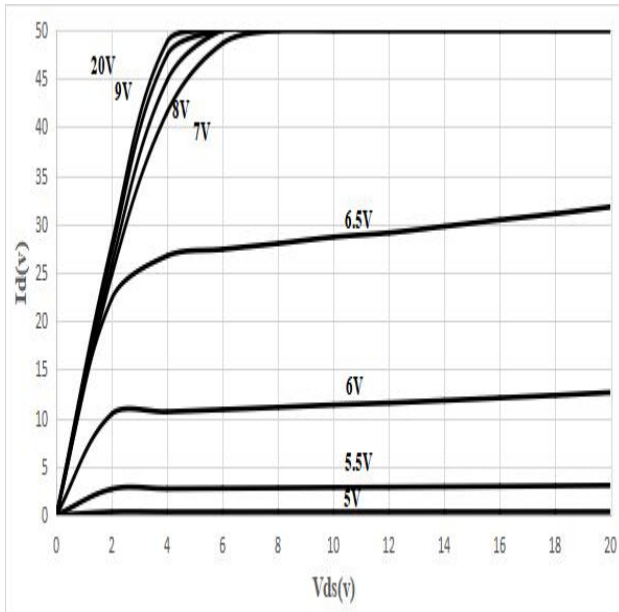
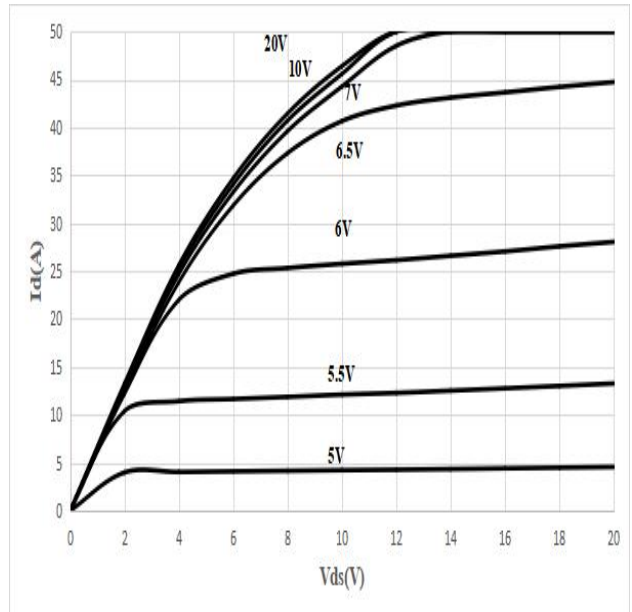
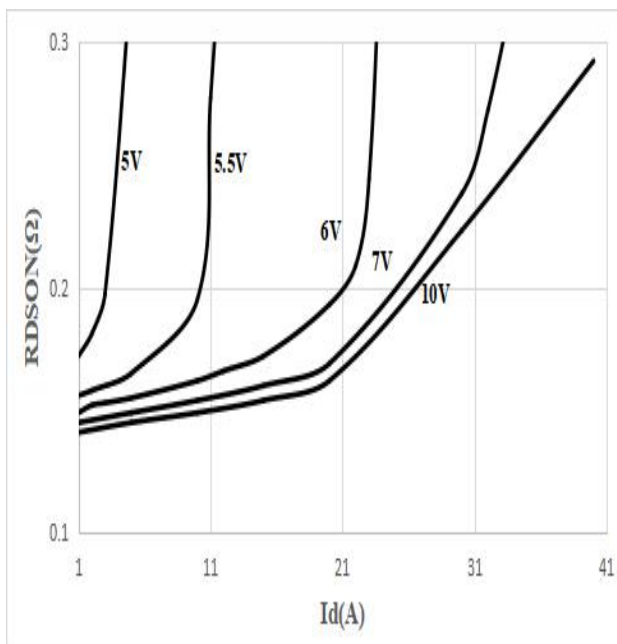
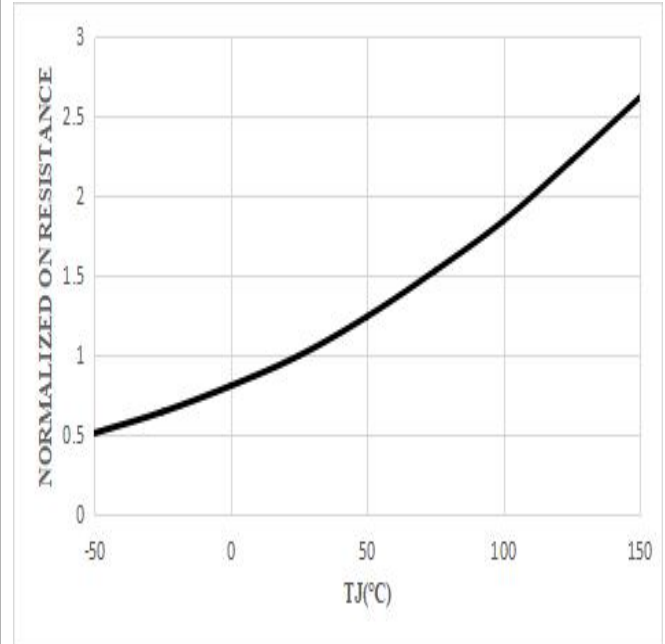
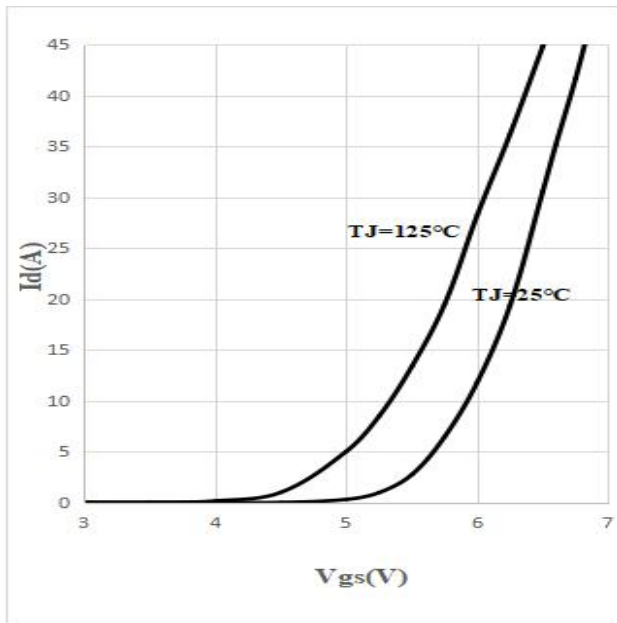
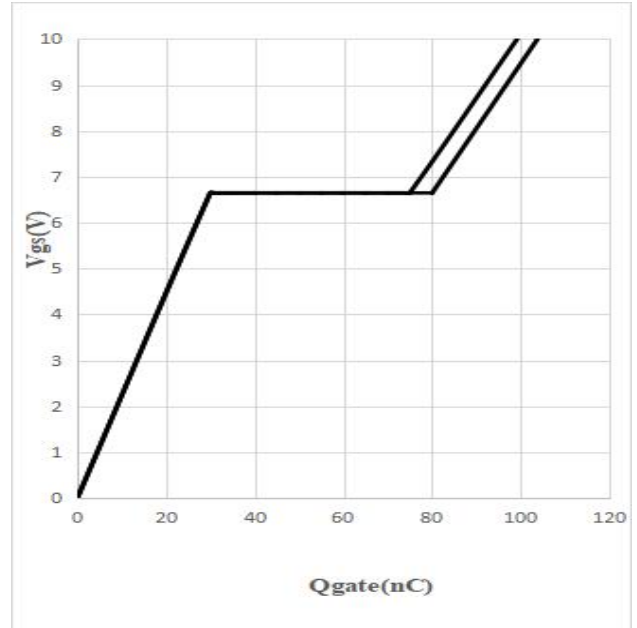
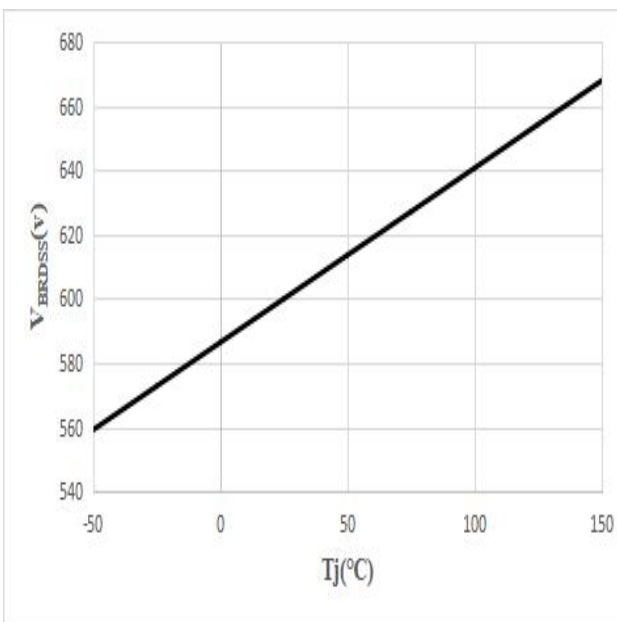
Figure 11: Typ. Transfer Characteristics

$$I_D = f(V_{GS}); V_{DS} = 20V$$

Figure 12: Typ. Gate Charge

$$V_{GS} = f(Q_{gate}), I_D = 21A \text{ pulsed}$$

Figure 13: Drain-Source Breakdown Voltage

$$V_{BR(DSS)} = f(T_j); I_D = 10mA$$

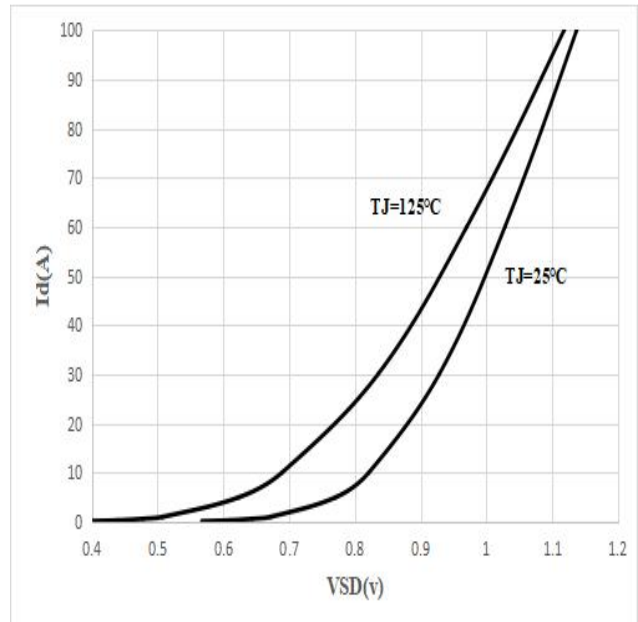
Figure 14: Forward Characteristics of Reverse Diode

$$I_F = f(V_{SD}); \text{parameter: } T_j$$

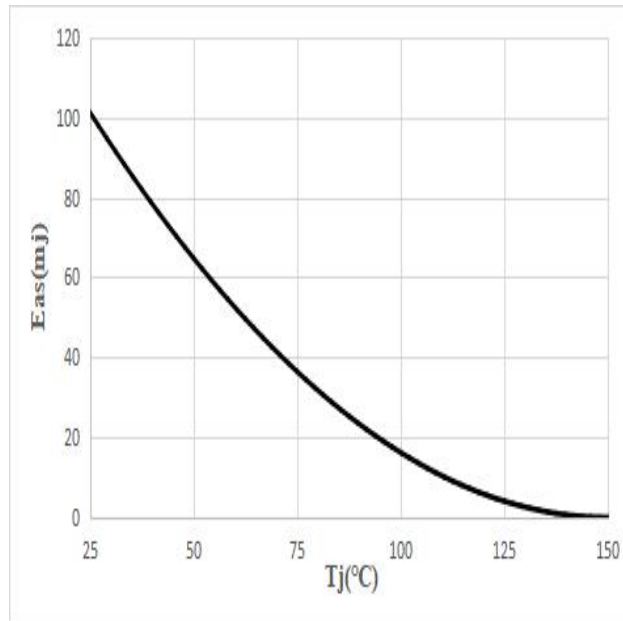
Figure 15: Avalanche Energy

$$E_{AS}=f(T_j); I_D=4.5A; V_{DD}=60V$$

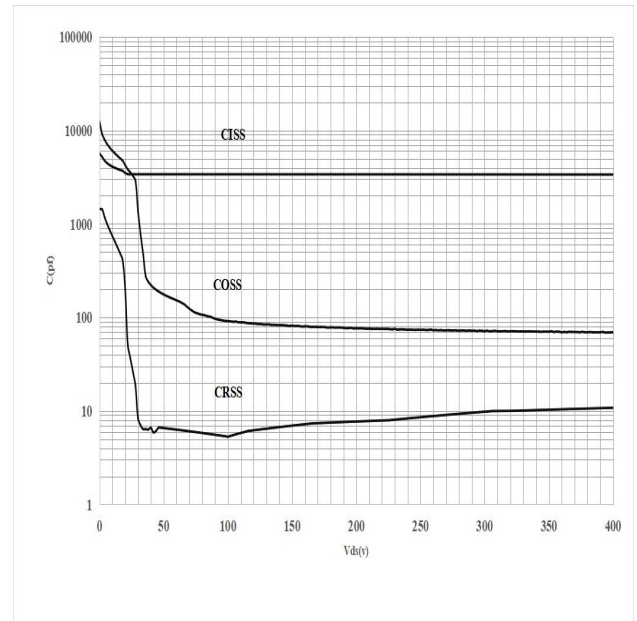
Figure 16: Typ. Capacitances

$$C=f(V_{DS}); V_{GS}=0; f=100kHz$$

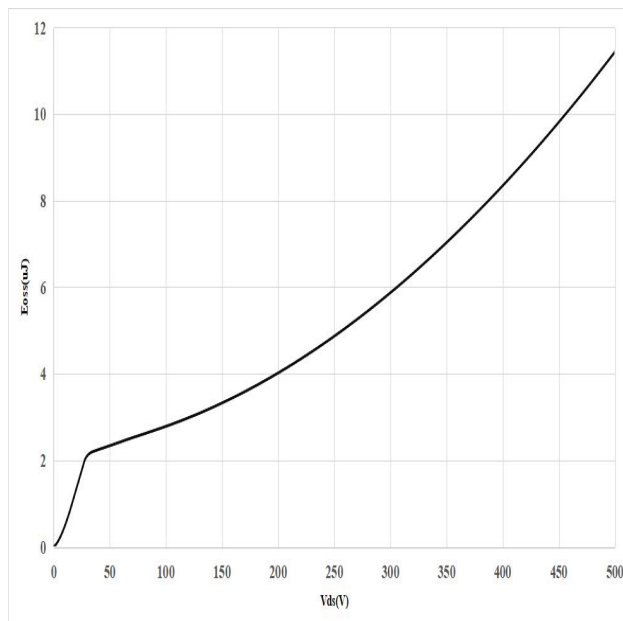
Figure 17: Coss Stored Energy

$$E_{OSS}=f(V_{DS})$$

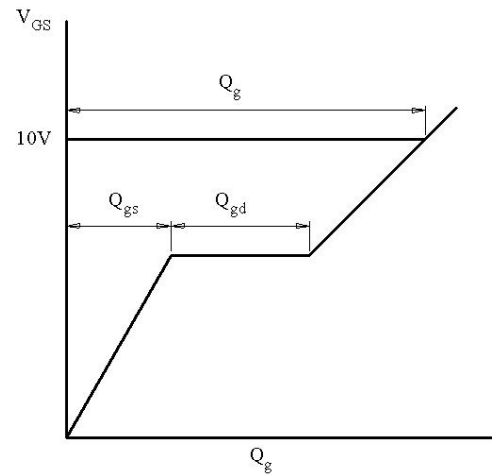
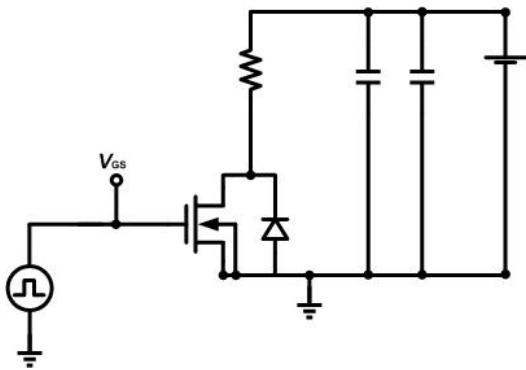
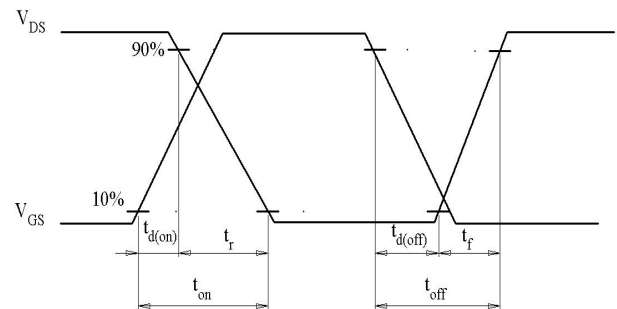
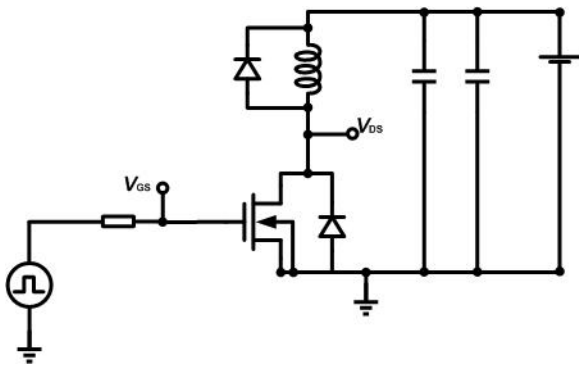
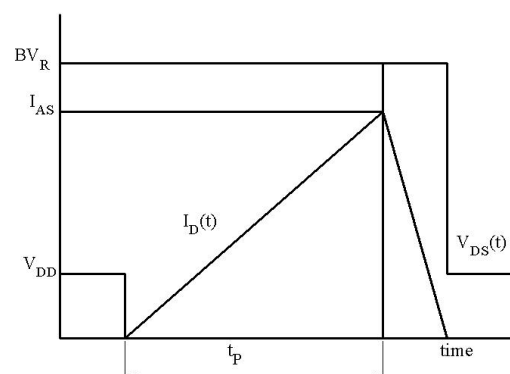
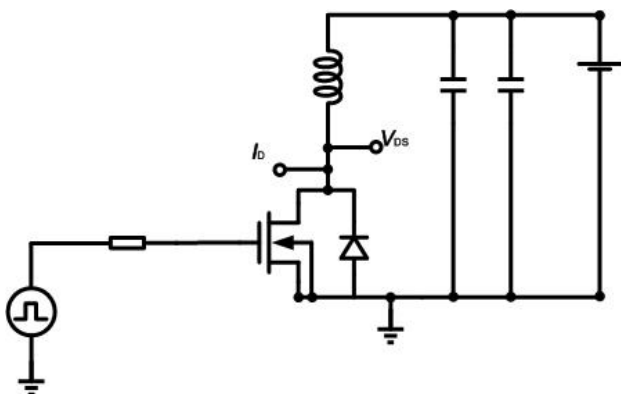
Test Circuits
1. Gate Charge Test Circuit & Waveform

2. Switch Time Test Circuit

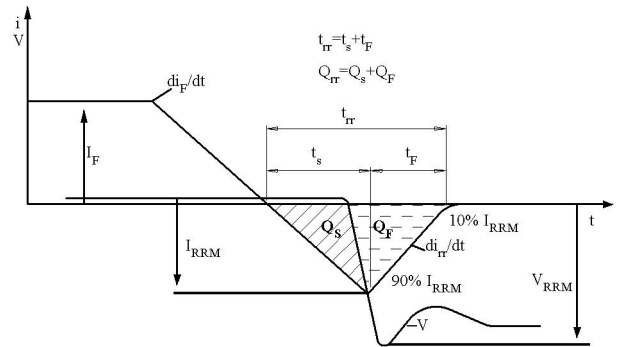
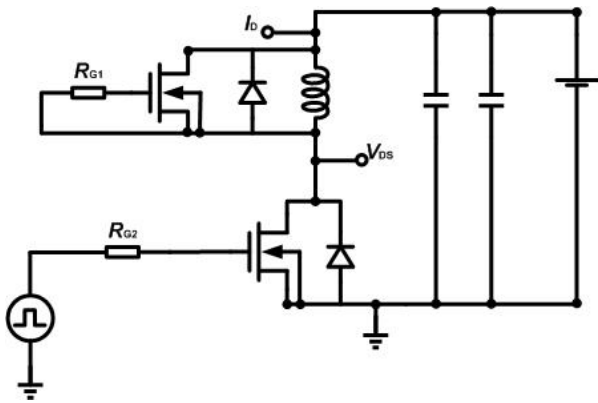
3. Unclaimed Inductive Switching Test Circuit & Waveforms

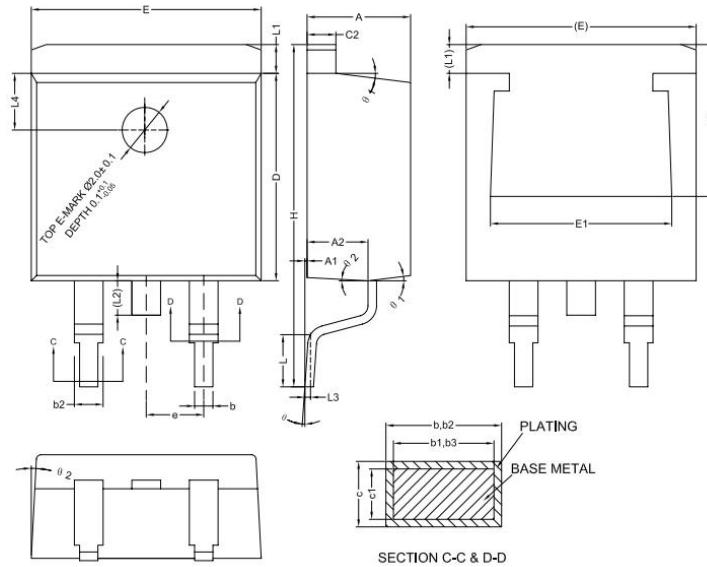
4. Test Circuit and Waveform for Diode Characteristics



Mechanical Dimensions
TO-263-2 (Package 1)
Unit: mm

Symbol	Dimensions(mm)		
	Min.	Typ.	Max.
A	4.40	4.57	4.70
A1	0.00	0.10	0.25
A2	2.59	2.69	2.79
b	0.77	-	0.90
b1	0.76	0.81	0.86
b2	1.23	-	1.36
b3	1.22	1.27	1.32
c	0.34	-	0.47
c1	0.33	0.38	0.43
c2	1.22	-	1.32
D	9.05	9.15	9.25
D1	6.60	-	-
E	10.06	10.16	10.26
E1	7.80	-	8.20
e	2.54(BSC)		
H	14.70	15.10	15.50
L	2.00	2.30	2.60
L1	1.17	1.27	1.40
L2	-	-	1.75
L3	0.25BSC		
L4	2.00REF		
θ	0°	-	8°
θ1	5°	7°	9°
θ2	1°	3°	5°

Mechanical Dimensions
TO-263-2 (Package 2)

Unit: mm

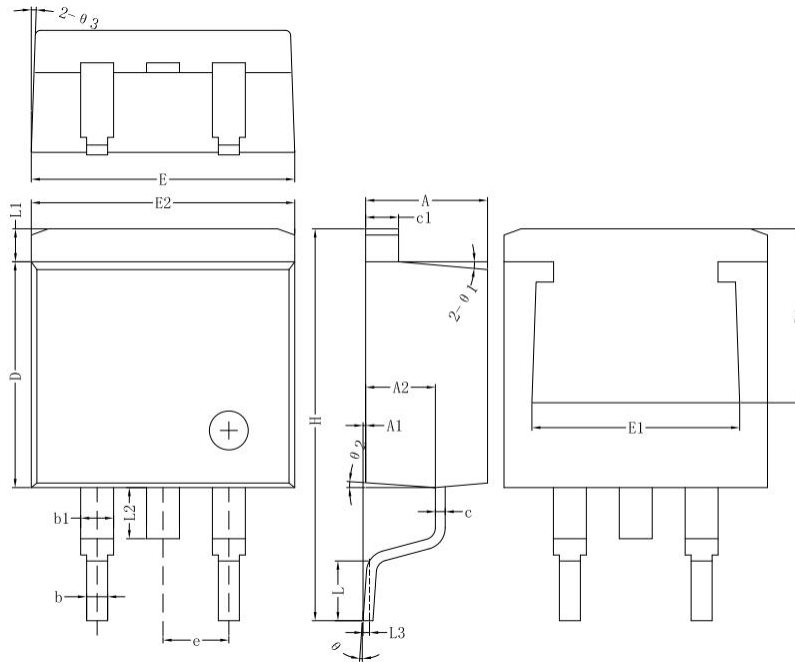

Symbol	Dimensions(mm)		
	Min.	Typ.	Max.
A	4.55	4.70	4.85
A1	0.00	0.10	0.25
A2	2.59	2.69	2.89
b	0.71	0.81	0.96
b1	-	1.27	-
c	0.36	0.38	0.61
c1	1.17	1.27	1.37
D	8.55	8.70	8.85
D1	-	7.2	-
E	10.01	10.16	10.31
E1	-	7.80	-
E2	9.98	10.08	10.18
e	-	2.54	-
H	14.70	15.10	15.50
L	2.00	2.30	2.70
L1	1.17	1.27	1.40
L2	-	-	2.20
L3	-	0.25BSC	-
θ	0°	-	8°
θ1		5°	
θ2		4°	
θ3		4°	

Mechanical Dimensions
TO-263-2 (Package 3)

Unit: mm

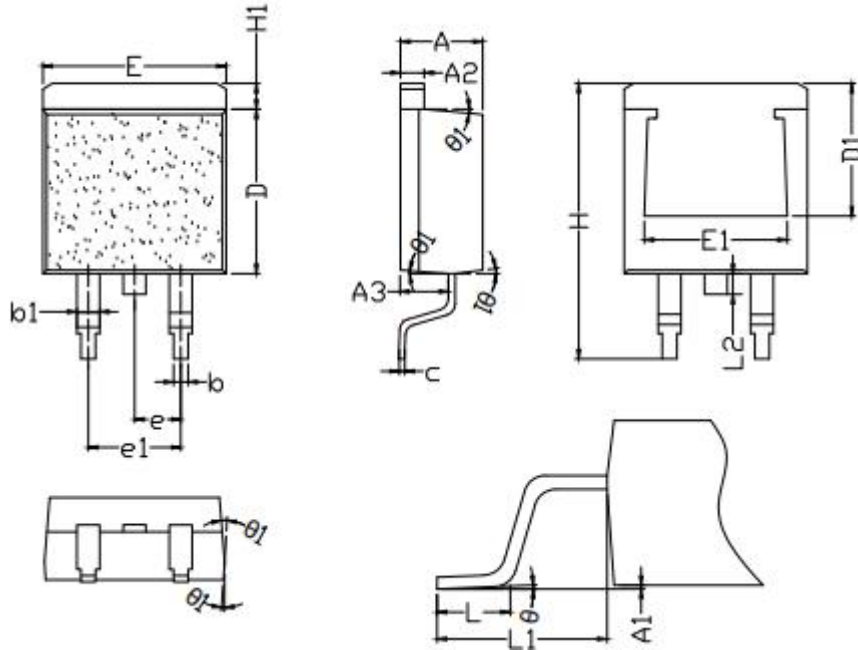

Symbol	Dimensions(mm)		
	Min.	Typ.	Max.
A	4.42	4.52	4.62
A1	0.00	0.10	0.25
A2	1.24	1.27	1.32
A3	2.50	2.60	2.70
b	0.77	0.81	0.84
b1	1.23	1.28	1.41
c	0.33	0.38	0.43
D	8.80	8.95	9.10
D1	7.2REF		
E	9.92	10.07	10.22
E1	7.85REF		
e	2.50	2.54	2.58
e1	5.08REF		
H	14.80	15.10	15.30
H1	1.12	1.28	1.42
L	2.10	2.23	2.36
L1	4.55	4.75	4.95
L2	1.10	1.30	1.50
θ	0°	2°	5°
θ1	3°	-	5°

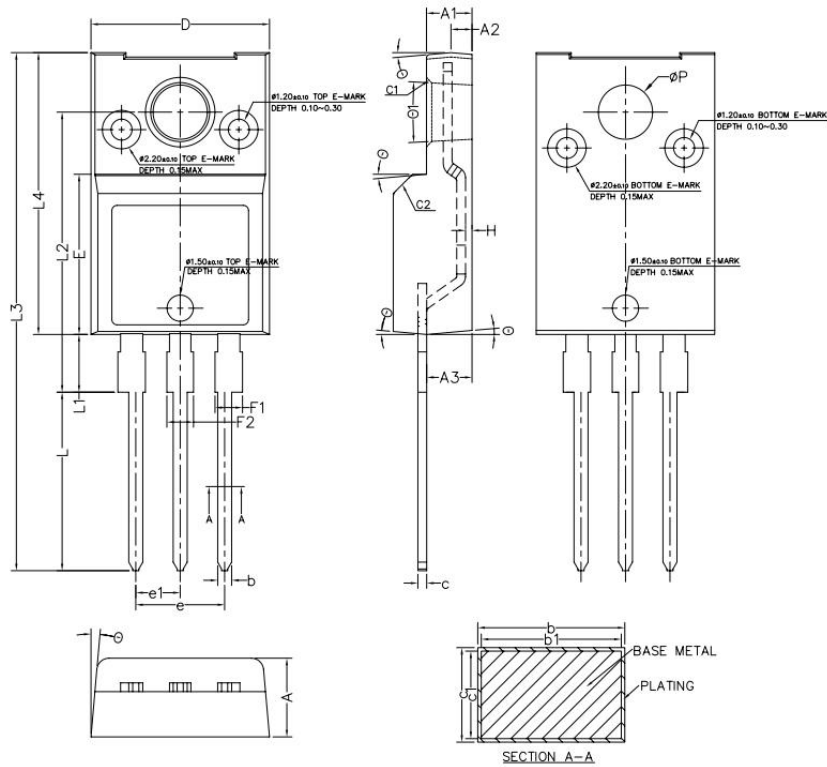
Mechanical Dimensions
TO-220F (Package 1)
Unit: mm

Symbol	Dimensions(mm)		
	Min.	Typ.	Max.
A	4.40	4.50	4.60
A1	2.50	2.60	2.70
A2	1.10	1.20	1.30
A3	2.49	2.59	2.69
b	0.76	-	0.89
b1	0.75	0.80	0.85
c	0.46	-	0.59
c1	0.45	0.50	0.55
C1	0.20	0.30	0.40
C2	1.00	1.10	1.20
D	10.10	10.20	10.30
E	9.05	9.15	9.25
e	4.98	5.08	5.18
e1	2.44	2.54	2.64
F1	1.22	-	1.60
F2	1.17	-	1.55
H	0.32	0.37	0.42
L	10.00	10.20	10.40
L1	3.15	3.30	3.45
L2	15.85	16.00	16.15
L3	29.30	29.60	29.90
L4	16.00	16.10	16.20
P	3.00	3.10	3.20
θ	3°	5°	7°
θ1	4°	6°	8°

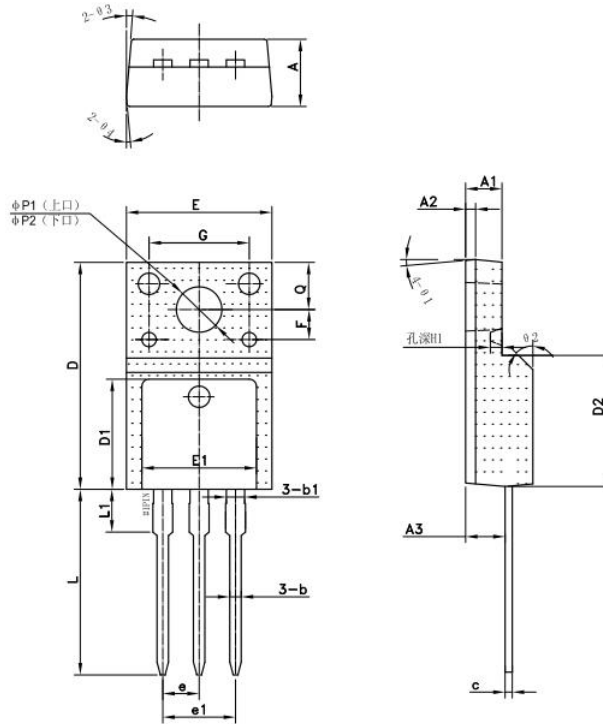
Mechanical Dimensions
TO-220F (Package 2)
Unit: mm

Symbol	Dimensions(mm)		
	Min.	Typ.	Max.
A	4.50	4.70	4.90
A1	2.34	2.54	2.70
A2	-	0.70	-
A3	2.56	2.76	2.96
b	0.70	0.80	0.95
b1	-	1.28	-
c	0.45	0.50	0.65
D	15.67	15.87	16.07
D1	-	7.70	-
D2	-	9.12	-
E	9.96	10.16	10.36
E1	-	8.00	-
e	2.54		
e1	5.08		
F	2.1		
G	7		
H1	-	0.81	-
L	12.48	12.98	13.20
L1	-	2.93	-
ΦP1 (上口)	2.98	3.18	3.38
ΦP2 (下口)	3.20	3.40	3.60
Q	3.10	3.30	3.50
θ1	5°		
θ2	45°		
θ2	5°		
θ3	5°		

Mechanical Dimensions
TO-220F (Package 3)

Unit: mm

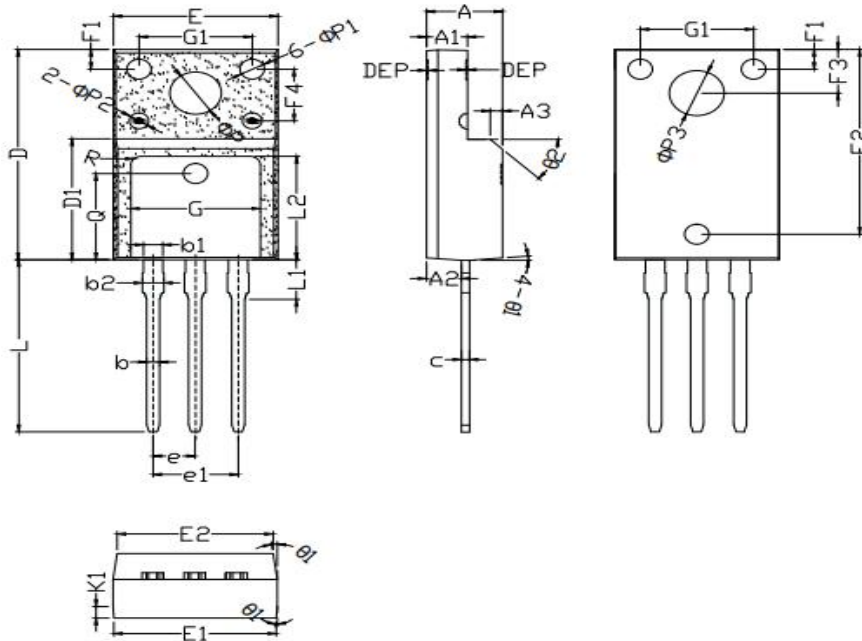

Symbol	Dimensions(mm)		
	Min.	Typ.	Max.
A	4.50	4.70	4.90
A1	2.34	2.54	2.74
A2	2.60	2.80	2.95
A3	1.0REF		
b	0.75	0.80	0.85
b1	1.18	1.20	1.24
b2	1.18	1.24	1.30
c	0.45	0.50	0.55
D	15.67	15.87	16.07
D1	9.04	9.12	9.20
E	10.00	10.16	10.30
E1	9.94	10.06	10.30
E2	9.40	9.50	9.60
e	2.50	2.54	2.58
e1	5.08REF		
L	12.78	12.98	13.18
L1	2.70	2.92	3.20
L2	7.70	7.80	7.90
Q	6.50REF		
ΦP	3.08	3.18	3.28
ΦP1	1.45	1.55	1.65
ΦP2	0.95	1.15	1.35
ΦP3	3.30	3.40	3.50
θ1	3°	5°	7°
θ2	42°	45°	48°
F1	1.40	1.50	1.60
F2	13.80	13.90	14.00
F3	3.20	3.30	3.40
F4	3.70	3.90	4.10
G	7.80	8.00	8.20
G1	6.90	7.00	7.10
K1	0.65	0.70	0.75

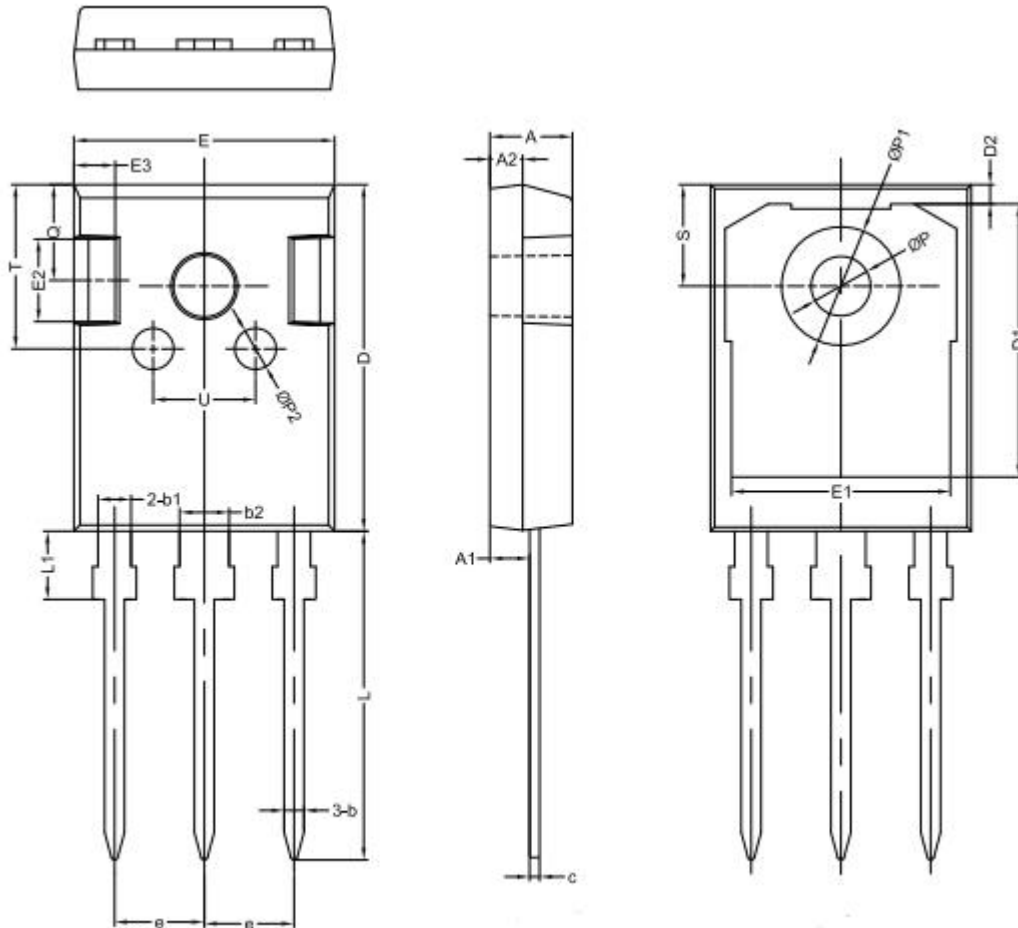
Mechanical Dimensions
TO-247(Package 1)
Unit: mm

Symbol	Dimensions(mm)			Symbol	Dimensions(mm)		
	Min.	Typ.	Max.		Min.	Typ.	Max.
A	4.80	5.00	5.20	E1	-	13.30	-
A1	2.21	2.41	2.61	E2	-	5.00	-
A2	1.90	2.00	2.10	E3	-	2.50	-
b	1.10	1.20	1.35	L	19.42	19.92	20.42
b1	-	2.00	-	L1	-	4.13	-
b2	-	3.00	-	P	3.50	3.60	3.70
c	0.55	0.60	0.75	P1	-	7.19	-
D	20.80	21.00	21.20	P2	-	2.50	-
D1	-	16.55	-	Q	-	5.80	-
D2	-	1.20	-	S	6.05	6.15	6.25
E	15.60	15.80	16.0	T	-	10.00	-
U	-	6.20	-				

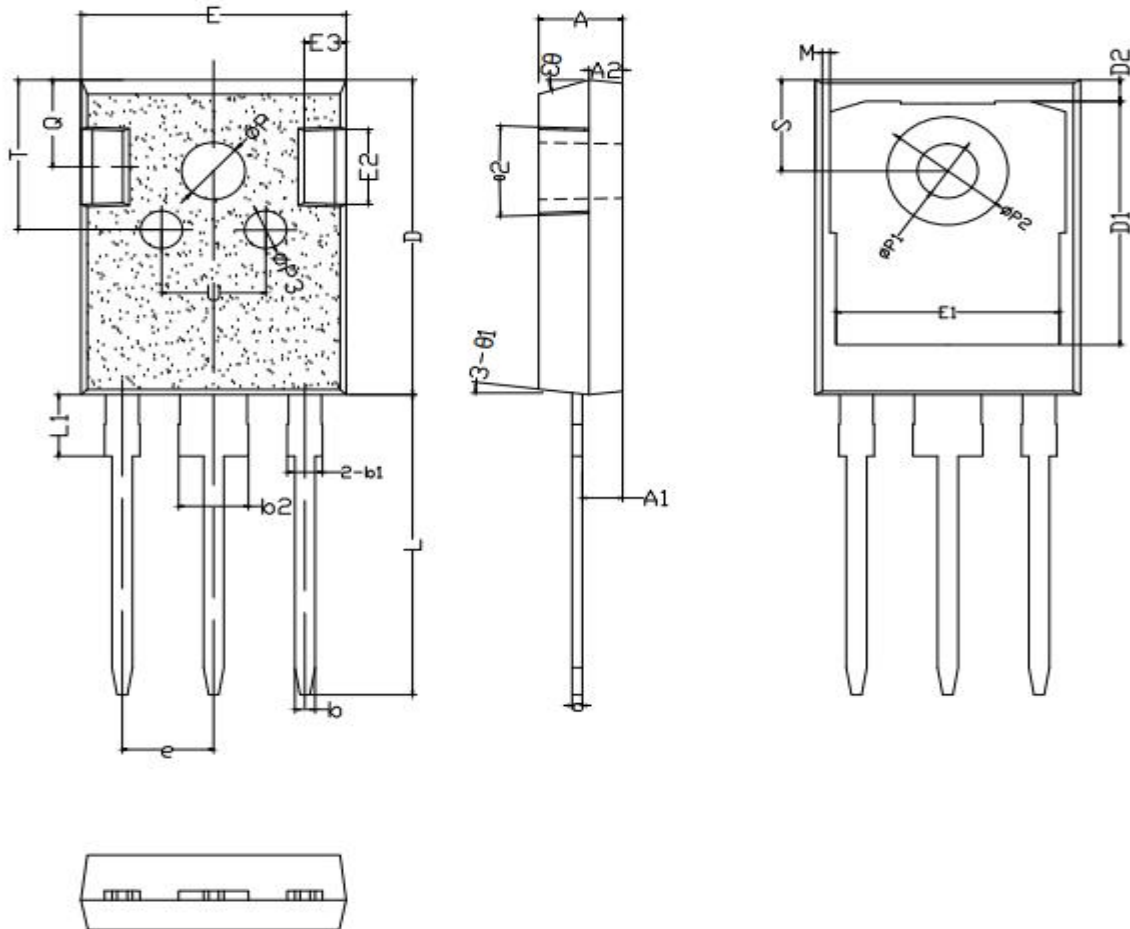
Mechanical Dimensions
TO-247(Package 2)
Unit: mm

Symbol	Dimensions(mm)			Symbol	Dimensions(mm)		
	Min.	Typ.	Max.		Min.	Typ.	Max.
A	4.90	5.00	5.10	E1	13.10	13.25	13.40
A1	2.31	2.41	2.51	E2	4.85	4.95	5.10
A2	1.90	2.00	2.10	E3	2.40	2.50	2.60
b	1.15	1.20	1.25	L	19.80	19.98	20.15
b1	1.95	2.10	2.25	L1	-	-	4.30
b2	2.95	3.10	3.25	ΦP	3.60	3.70	3.80
c	0.55	0.60	0.65	ΦP1	3.40	3.50	3.60
D	20.90	21.00	21.10	ΦP2	6.90	7.10	7.30
D1	16.35	16.55	16.75	Q	5.60	5.80	6.00
D2	1.05	1.20	1.35	S	6.05	6.15	6.25
E	15.70	15.80	15.90	T	9.80	10.00	10.20
U	6.00	6.20	6.40	e	5.40	5.44	5.48
Θ1	5°	7°	9°	ΦP3	2.40	2.50	2.60
Θ2	1°	3°	5°	Θ3	13°	15°	17°

Mechanical Dimensions
TO-247(Package 4)

Unit: mm

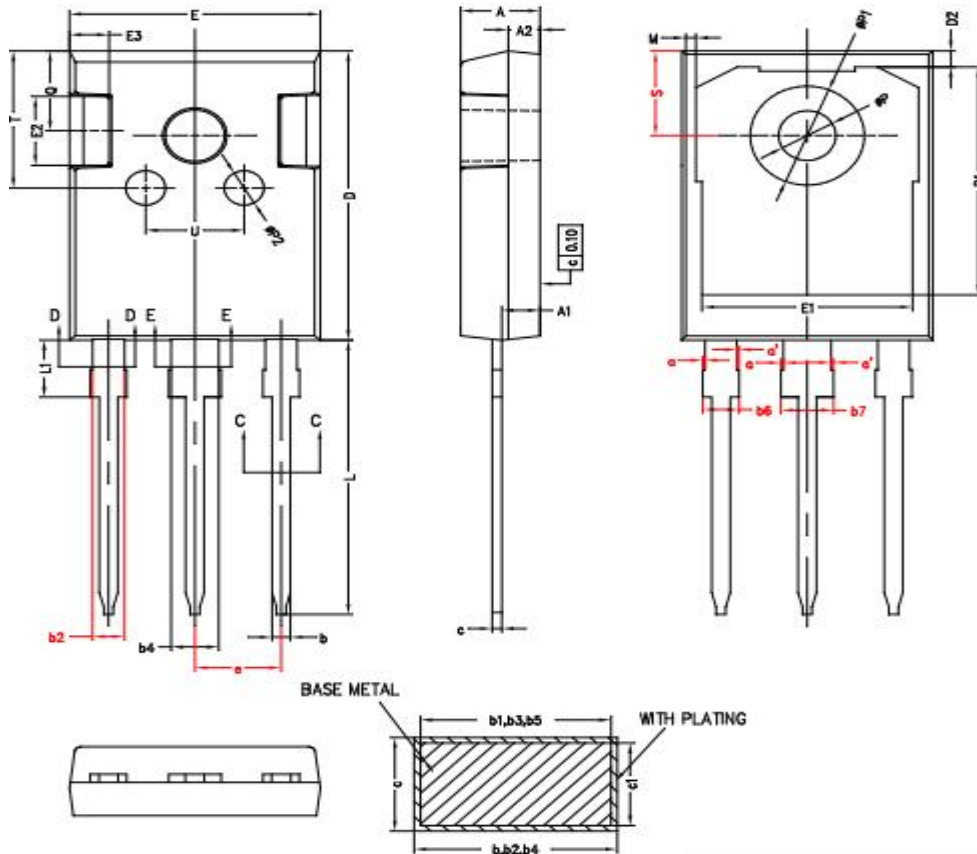

Symbol	Dimensions(mm)			Symbol	Dimensions(mm)		
	Min.	Typ.	Max.		Min.	Typ.	Max.
A	4.90	5.00	5.10	E2	4.90	5.00	5.10
A1	2.31	2.41	2.51	E3	2.40	2.50	2.60
A2	1.90	2.00	2.10	e	5.34	5.44	5.54
b	1.12	-	1.22	L	19.80	19.92	20.10
b1	1.11	1.16	1.18	L1	3.95	4.13	4.30
b2	1.96	-	2.06	P	3.50	3.60	3.70
c	0.59	-	0.66	P1	7.00	-	7.40
D	20.90	21.00	21.10	P2	2.40	2.50	2.60
D1	16.25	16.55	16.85	Q	5.60	-	6.00
D2	1.05	1.20	1.35	S	6.05	6.15	6.25
E	15.70	15.80	15.90	T	9.80	-	10.20
E1	13.10	13.30	13.50	U	6.00	-	6.40
b3	1.95	2.00	2.02	b6	-	-	2.25
b4	2.96	-	3.06	b7	-	-	3.25
b5	2.95	3.00	3.02	c1	0.58	0.60	0.62
M	0.35	-	0.95	a	0	-	0.15
a'	0	-	0.15				

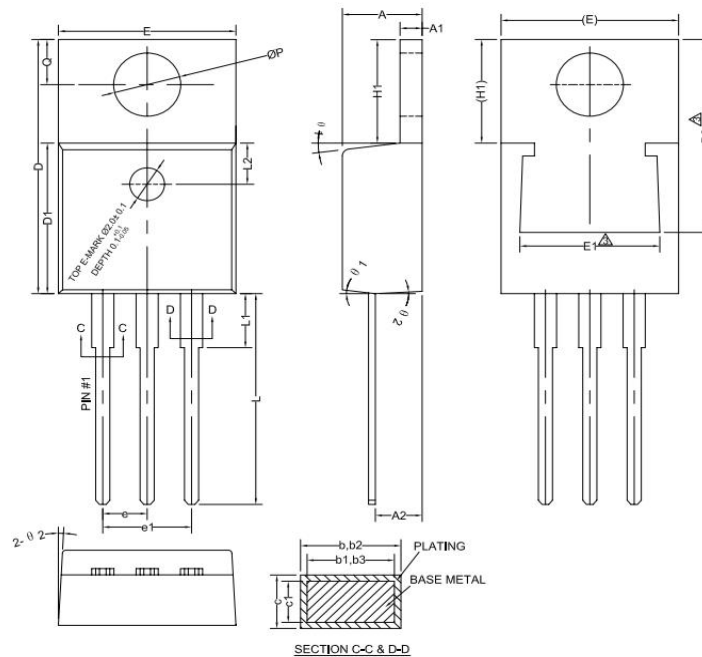
Mechanical Dimensions
TO-220C (Package 1)
Unit: mm

Symbol	Dimensions(mm)		
	Min.	Typ.	Max.
A	4.40	4.57	4.70
A1	1.22	-	1.32
A2	2.59	2.69	2.79
b	0.77	-	0.90
b1	0.76	0.81	0.86
b2	1.23	-	1.36
b3	1.22	1.27	1.32
c	0.34	-	0.47
c1	0.33	0.38	0.43
D	15.15	15.45	15.75
D1	9.05	9.15	9.25
D2	11.40	-	12.88
E	9.96	10.16	10.36
E1	6.86	-	8.89
e	2.44	2.54	2.64
e1	4.98	5.08	5.18
H1	6.10	6.30	6.50
L	12.70	-	13.12
L1	-	-	3.90
ØP	3.80	3.84	3.88
Q	2.60	-	2.90
θ1	5°	7°	9°
θ2	1°	2°	5°

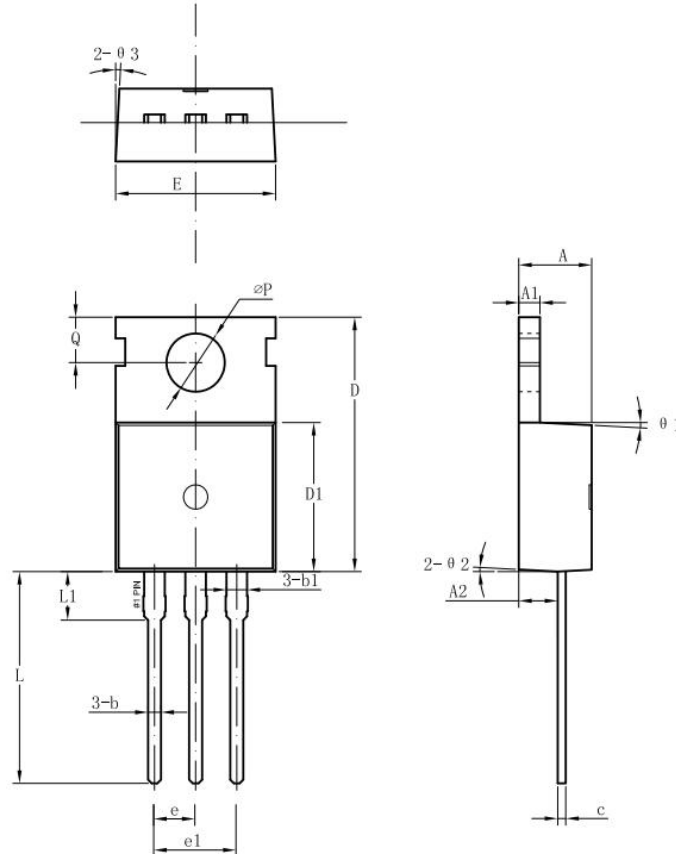
Mechanical Dimensions
TO-220C (Package 2)
Unit: mm

Symbol	Dimensions(mm)		
	Min.	Typ.	Max.
A	4.30	4.50	4.70
A1	1.25	1.30	1.40
A2	2.20	2.40	2.60
b	0.70	0.80	0.95
b1	-	1.27	-
c	0.40	0.50	0.65
D	15.20	15.70	16.20
D1	9.00	9.20	9.40
E	9.70	10.00	10.20
e		2.54	
e1		5.08	
L	12.60	13.08	13.60
L1	-	3.00	-
ΦP	3.50	3.60	3.80
Q	2.60	2.80	3.00
θ1		3°	
θ2		3°	
θ2		3°	

Mechanical Dimensions
TO-220C (Package 3)

Unit: mm

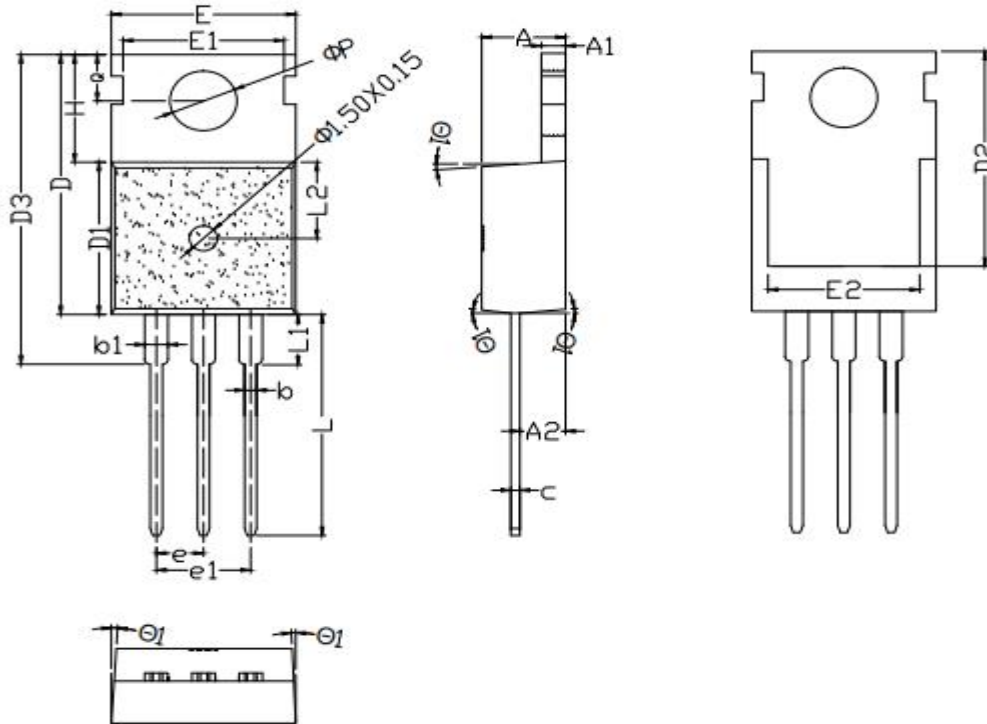

Symbol	Dimensions(mm)		
	Min.	Typ.	Max.
A	4.40	4.50	4.60
A1	1.25	1.30	1.35
A2	2.30	2.40	2.50
b	0.70	0.80	0.90
b1	1.25	1.33	1.42
c	0.45	0.50	0.55
D	15.50	15.75	16.00
D1	9.10	9.20	9.30
D2	12.90	13.10	13.30
D3	15.45	15.80	16.15
E	9.80	10.02	10.15
e	2.54BSC		
e1	5.08BSC		
L	13.00	13.28	13.45
L1	-	-	3.40
ΦP	3.55	3.65	3.75
Q	2.65	2.75	2.85
$\theta 1$	2°	-	7°
E1	8.55	8.70	8.85
E2	7.40	7.60	7.80
H	6.40	6.50	6.60
L2	4.50	4.65	4.80



Shenzhen Sanrise Technology Co., LTD.

<http://www.sanrise-tech.com>

IMPORTANT NOTICE

Shenzhen Sanrise Technology Co., LTD. reserves the right to make changes without further notice to any products or specifications herein. Shenzhen Sanrise Technology Co., LTD. does not assume any responsibility for use of any its products for any particular purpose, nor does Shenzhen Sanrise Technology Co., LTD. assume any liability arising out of the application or use of any its products or circuits. Shenzhen Sanrise Technology Co., LTD. does not convey any license under its patent rights or other rights nor the rights of others.

Main Site:

- Headquarter

Shenzhen Sanrise Technology Co., LTD.
A1206, Skyworth building, No. 008, gaoxinnan 1st Road,
Gaoxin District, Yuehai street,, Nanshan District, ShenZhen,
P.R.China

Tel: +86-755-22953335

Fax: +86-755-22916878

- Shanghai Office

Shenzhen Sanrise Technology Co., LTD.
Rm.401, Building B, No. 666, Zhangheng Road,
Zhangjiang Hi-Tech Park, Shanghai, P.R.China

Tel: +86-21-68825918